

**EMPARRO67 POWER SUPPLY 1-PHASE**

IN: 100-240VAC OUT: 24VDC/8A

Emparro®67

INPUT: 90...265 V AC/90...265 V DC

OUTPUT: 24 V DC (SELV), ±2%

Current: 8 A

[Link to Product](#)**Illustration**

Product may differ from Image

**Approvals****Input**

Input voltage	90...265 V AC/90...265 V DC
Input current	2.1 A (100 V AC); 0.9 A (240 V AC)
Inrush current after 1 ms	max. 7 A (230 V AC)
Power factor	0.95 (230 V AC)
Connection	7/8" (male), 3-pole
Frequency	50...60 Hz
Input fuse (internal)	6.3 A (T)

**Output**

Output voltage	24 V DC (SELV), ±2%
Power Boost	I <sub>out</sub> N × 150% (min. 4 s)
Output current	8 A
Connection	7/8" (female), 5-pole
Mains failure bridging time	min. 35 ms (230 V AC); 8 A (24 V DC)
Ripple	max. 30 mV eff/rms
Spikes	max. 300 mV ss/pp
Unit protection	Short-circuit, overload and temperature
LED display	LED (green): OK; LED (red): overload, overheating or short-circuit

Parallel usage/serial usage                      max. 3 units/max. 2 units

#### General data

Standards	EN 60950-1, EN 61204-3, EN 55011 A, EN 61000-3-2
Relative humidity	4...100%
Protection	IP67
Efficiency	93.5% (115 V AC); 94.2% (230 V AC)
Mounting method	6 hole screw mounting
Temperature range	-40...+60 °C, ...+70 °C derating (storage temperature -40...+80 °C)
Dimensions H×W×D	51×109×175 mm

#### Commercial data

country of origin	CZ
customs tariff number	85044090
EAN	4048879482677
eClass	27049002
Packaging unit	1

#### Sketch

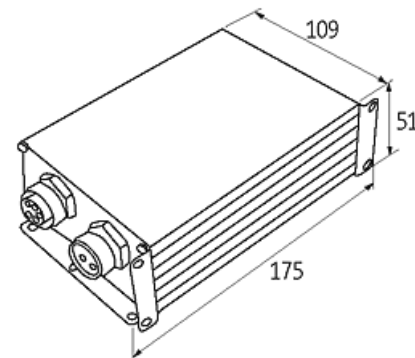

Product may differ from Image